



STAINLESS STEEL CYCLONIC POST SUPPORTS

JUN23

Compliant with the requirements of AS1684 and AS1720.

304 STAINLESS STEEL

316 STAINLESS STEEL

CYCLONIC

CAST INTO CONCRETE

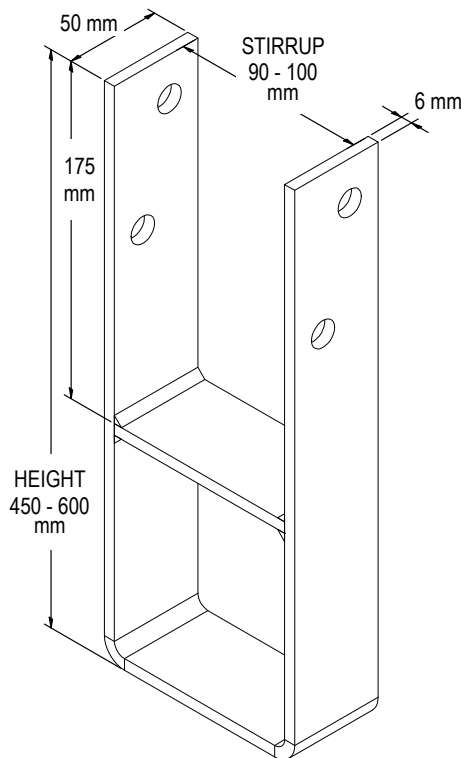

APPLICATION

The VUETRADE Cyclonic Post Support is engineered and designed for use in cyclone-prone and high wind areas. The U-shaped base provides excellent anchorage when set into concrete to withstand the large force imposed by high winds and cyclones.

SPECIFICATION

VUETRADE Cyclonic Post Supports are manufactured out of Stainless Steel 304 and 316 in 6mm thickness.

Use of stainless steel is recommended in applications where a high corrosion risk is expected and where hot-dipped galvanised corrosion protection is inadequate. Stainless Steel 316 has better corrosion protection characteristics than SS304 due to the presence of molybdenum in SS316.

FASTENERS

Saddle: 2x Stainless Steel VUEBOLT or appropriate M12 bolts with hex nuts

Only use stainless steel fasteners (bolts) with stainless steel post support, usage of other steel materials may lead to bimetallic corrosion.

SIZES

Product Code	Height (mm)	Stirrup Size (mm)	Box Qty
VCYPS45090SS	450	90	6
VCYPS450100SS	450	100	6
VCYPS60090SS	600	90	6
VCYPS600100SS	600	100	6

* Custom sizes are also available, refer to the VUETRADE Stainless Steel Cyclonic Post Support webpage.

NOTE:

'Tea-staining' is a cosmetic issue with some VUETRADE Stainless Steel Post Supports (more prevalent in SS304) but this does not affect the structural integrity or material lifetime of the post support.

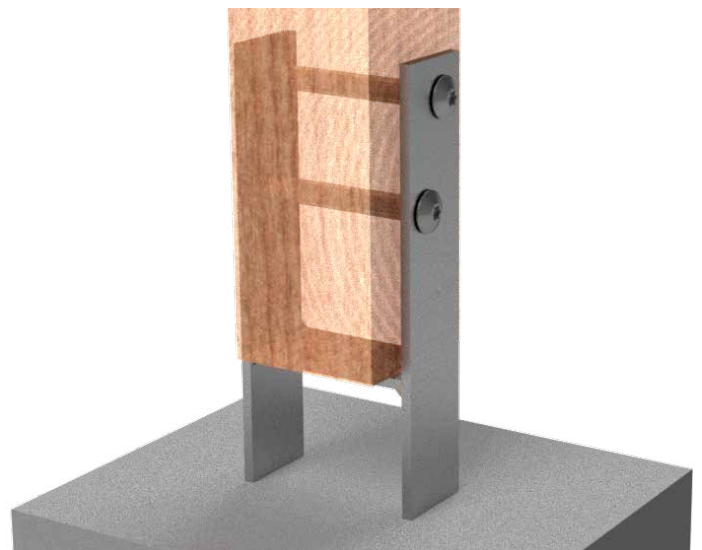



STAINLESS STEEL CYCLONIC POST SUPPORTS

JUN23

INSTALLATION GUIDE AND BOLT FIXING SCHEDULE

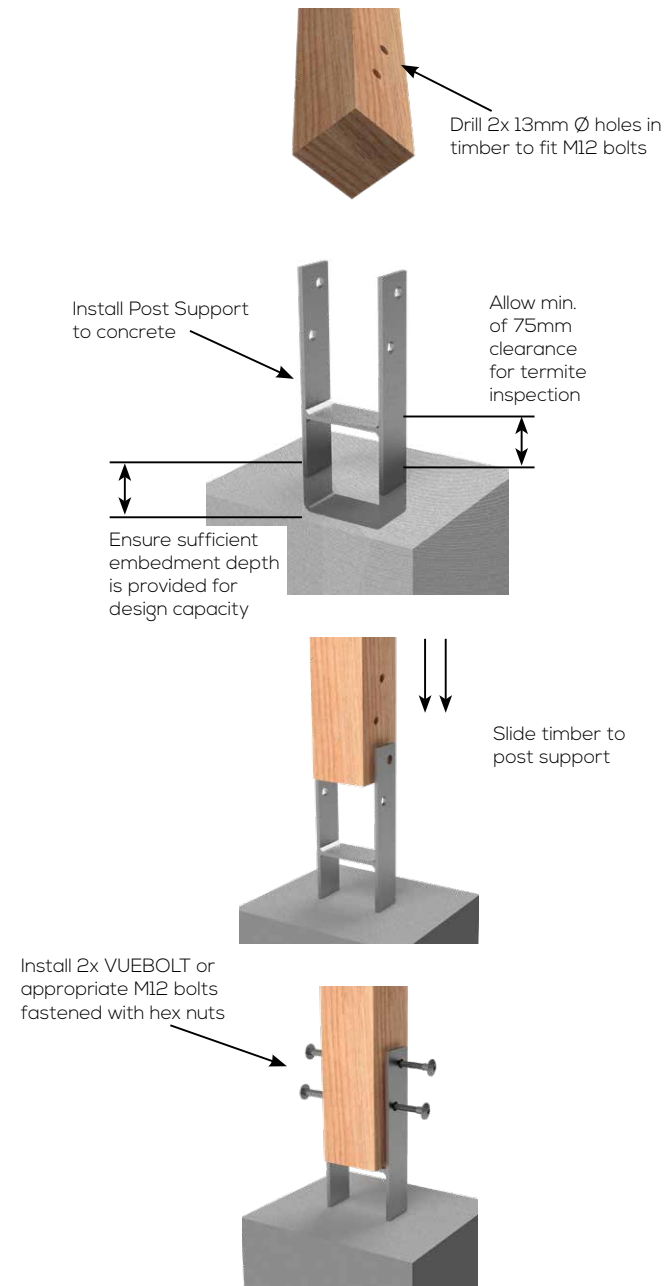

NOTES:

1. Embedment depth of the cyclonic post support should be determined and calculated by a Structural Engineer in order to achieve the reported design load. This usually depends on the type of concrete used, aggregate ratio etc.
2. 75mm clearance must be provided to conform to the requirements set out by AS3660.1:2014 - *Termite management, Part 1: New building work*.
3. Use only Stainless Steel M12 bolts when fastening with a Stainless Steel post support; do not use galvanised bolts as it may lead to accelerated corrosion to the post support and the bolts.
4. Refer to AS1684.3:2021 Table 9.20 (j) for reinforced rod installation requirements.

DESIGN CAPACITY DATA

Table 1: Design capacity of stainless steel cyclonic post support

Load Directions	Design Capacity, Ndj (kN) for timber species group JD4
Wind Uplift	41 kN

NOTES:

1. The design capacity in Table 1 applies to VUETRADE cyclonic post support where 2x M12 bolts are installed and tightly fastened with nuts.
2. Timber post dimensions must have minimum dimensions of 90mm by 90mm section and shall be installed flat to the base of the cyclonic post support.
3. The design capacities are calculated based on the assumption that there is sufficient anchorage in the concrete to resist the pull-out force imposed by wind loading.
4. Design capacity in above table is for wind uplift (vertical force direction) only and are obtained under the test conditions set out in AS1649-2001 - *Timber - Methods of test for mechanical fasteners and connectors*.
5. VUETRADE Post Supports should only be used to resist wind uplift / dead load as specified in the TDS and should not be assumed to provide lateral stability. Sufficient bracing should be provided and approved by a structural engineer for lateral stability.

