



GALVANISED INTERNAL WALL BRACKETS

JUN23

Compliant with the requirements of AS1684 and AS4440.

G GALVANISED

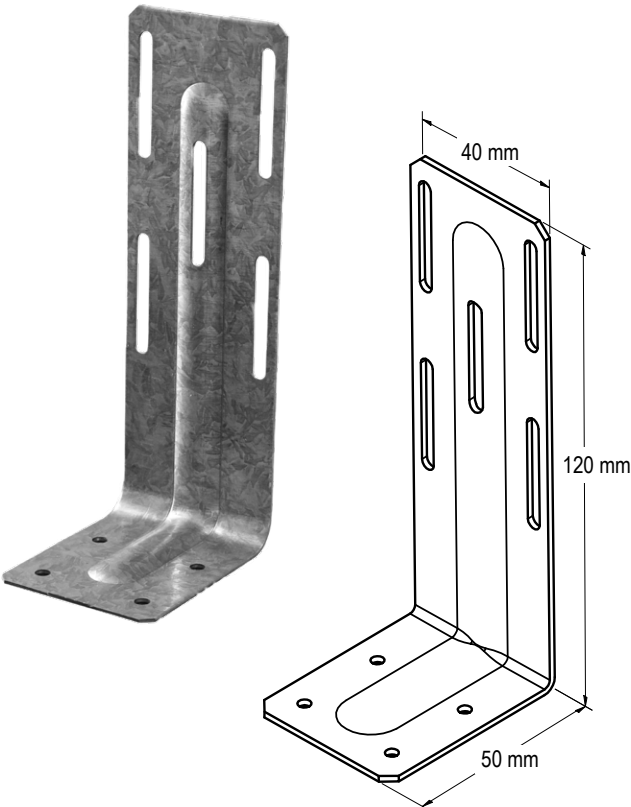

APPLICATION

VUETRADE Internal Wall Bracket is used for lateral movement restraint of wall top plates when installed to internal walls. Elongated nail hole patterns specifically designed to allow vertical movement without applying additional loads to walls.

SPECIFICATION

VUETRADE Internal Wall Bracket is manufactured with 1.0mm thick G300 Z275 steel.

FASTENERS

Nails: Use only VUETRADE 30mm x 2.8mm Ø Galvanised Connector Plate Nails

SIZES

Product Code	Nominal Size (mm)	Box Qty
VTPA47	120 x 50 x 40 x 1	100

INSTALLATION GUIDE

As required by AS1684 Clause 6.2.5.2, non-loadbearing walls shall have a gap of minimum 10mm between bottom chord/ ceiling battens and non-loadbearing walls. VUETRADE Internal Wall Bracket satisfy the installation requirement of AS1684 cl 6.2.5.2 of a slotted bracket to allow vertical movement of truss.

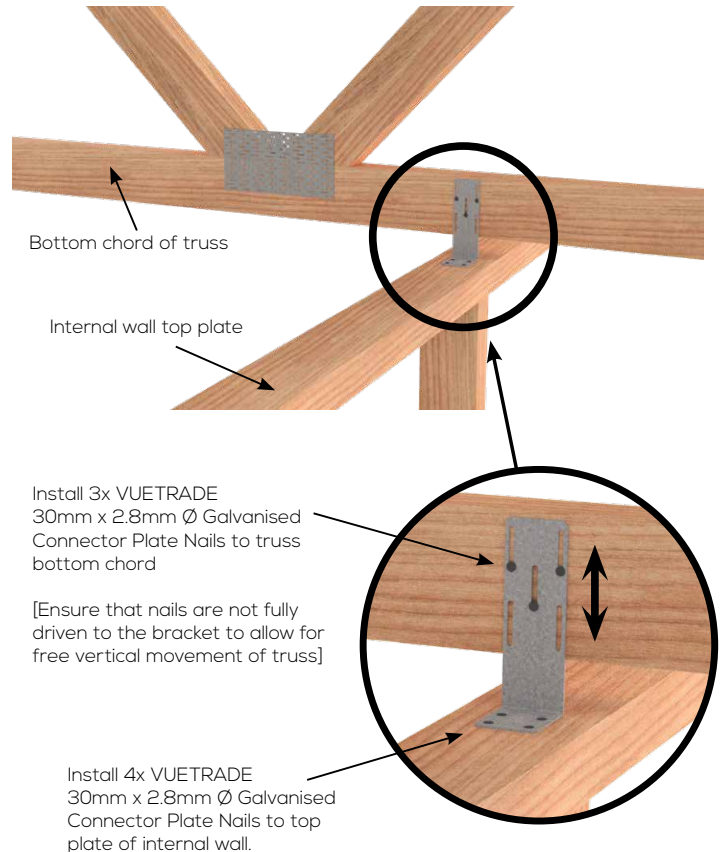

NOTES:

1. Ensure that 10mm gap is provided below bottom chord / batten as required in AS1684.
2. Do not drive nails on vertical face fully home to allow for free vertical movement of bottom chord
3. Extra nailing slots are provided where additional nails are required.
4. Internal Wall Bracket shall be fixed at 1800mm centres as recommended in AS1684 cl 6.2.5.2.

