



# GALVANISED SPLIT JOIST HANGERS

JUN23

Compliant with the requirements of AS1684 and AS1720. Designed and tested to AS1649.

**G GALVANISED**



VUESPIKES

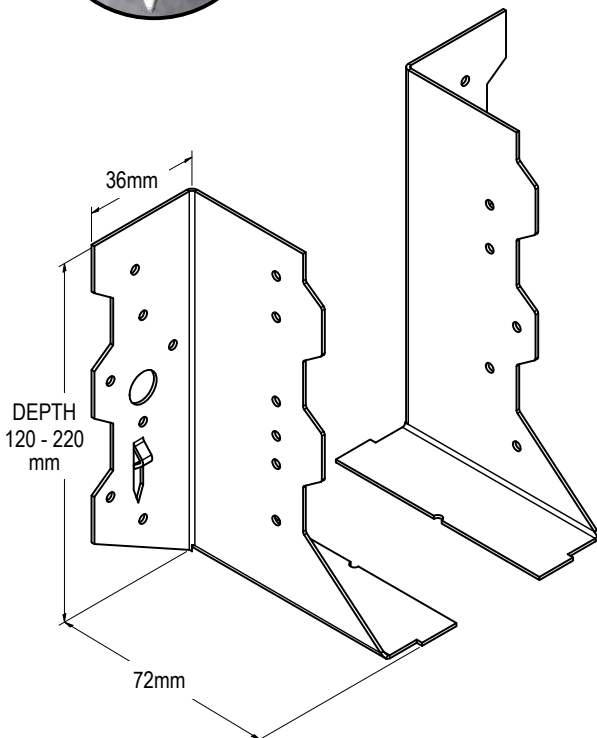

## APPLICATION

VUETRADE Split Joist Hangers are fast fixing, multi-purpose hangers for joist, beam and truss connections where timber is over the width of 50mm, to be installed as a pair.

## SPECIFICATION

VUETRADE Galvanised Split Joist Hangers are Australian Made with a galvanised finish (G300 Z275).

## FASTENERS

**Nails:** Use only VUETRADE 30mm x 2.8mm Ø Galvanised Connector Plate Nails

## SIZES

Product Code	Size (mm)	Box Qty
VSJH120	120	30 pairs
VSJH140	140	30 pairs
VSJH180	180	30 pairs
VSJH220	220	20 pairs

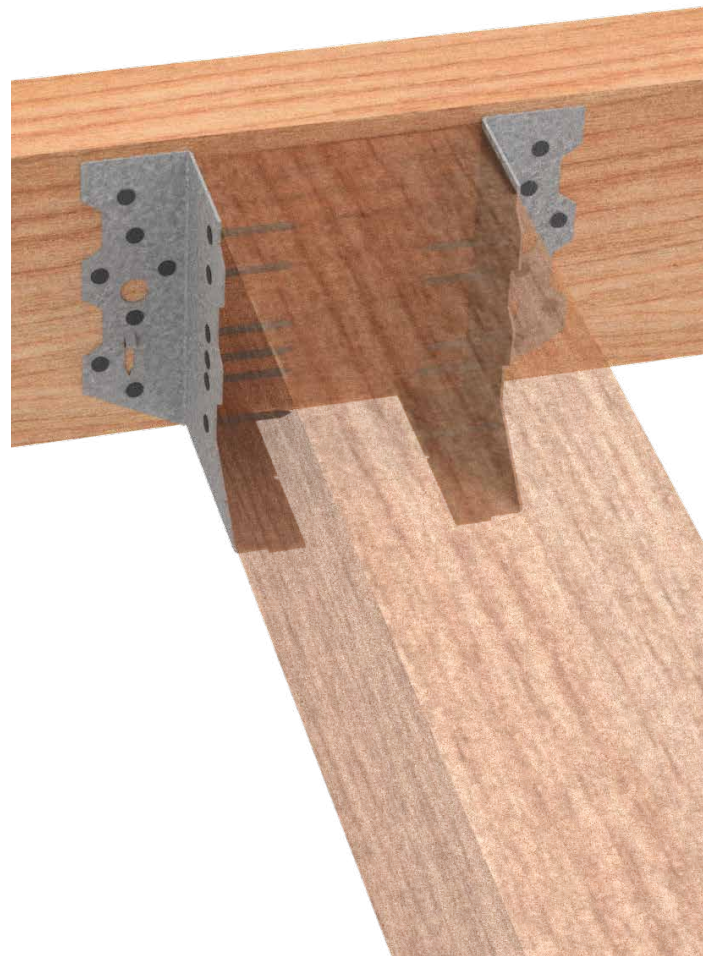



**GALVANISED SPLIT JOIST HANGERS**

JUN23

**INSTALLATION GUIDE**

For each side of the supported timber, position the Split Joist Hanger and fasten VUESPIKE to hold the hanger in place.

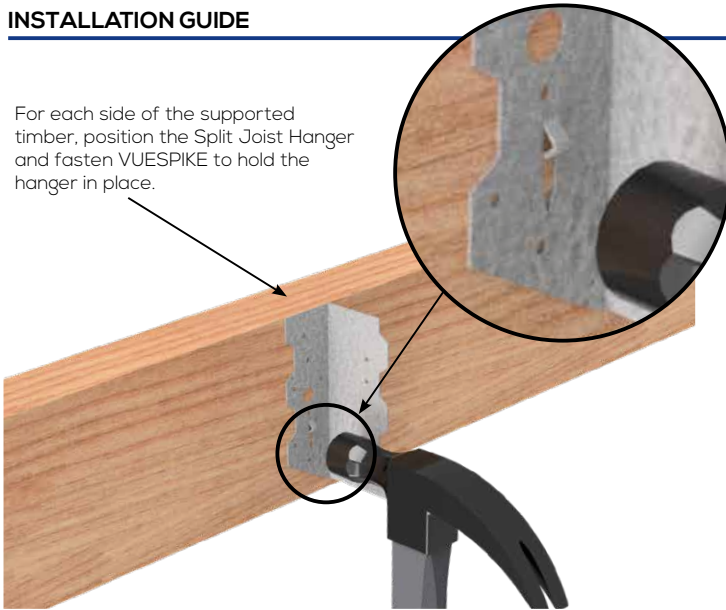

1. Suitable size Split Joist Hanger shall be selected using Product Sizes table on previous page, ensuring sufficient hanger depth is provided for different joist / beam sizes.
2. Both sides of the Split Joist Hanger should be fixed to the supporting member first. It can be quickly and easily held in place by VUESPIKES before fastening hanger with nails.
3. Fix VUETRADE 30mm x 2.8mm Ø Galvanised Connector Plate Nails through Split Joist Hanger to supporting beam, using the recommended number of nails in Table 1.
4. Install supported beam (usually floor beams / joists) to hangers and fasten supported beams with VUETRADE 30mm x 2.8mm Ø Galvanised Connector Plate Nails, using recommended number of nails listed in Table 1.

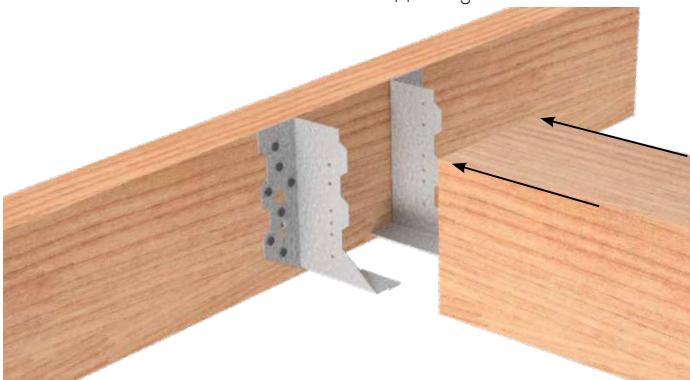
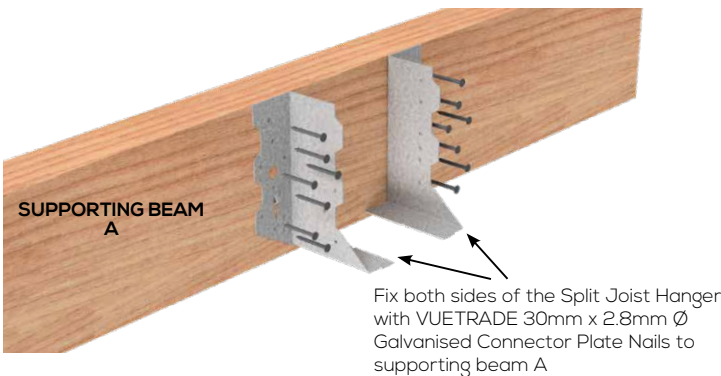

Fix supported beam B to the two sides of the Split Joist Hanger with VUETRADE 30mm x 2.8mm Ø Galvanised Connector Plate Nails

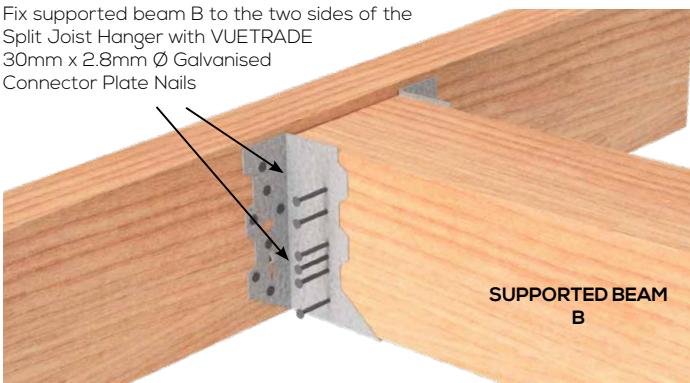



**GALVANISED SPLIT JOIST HANGERS**

JUN23

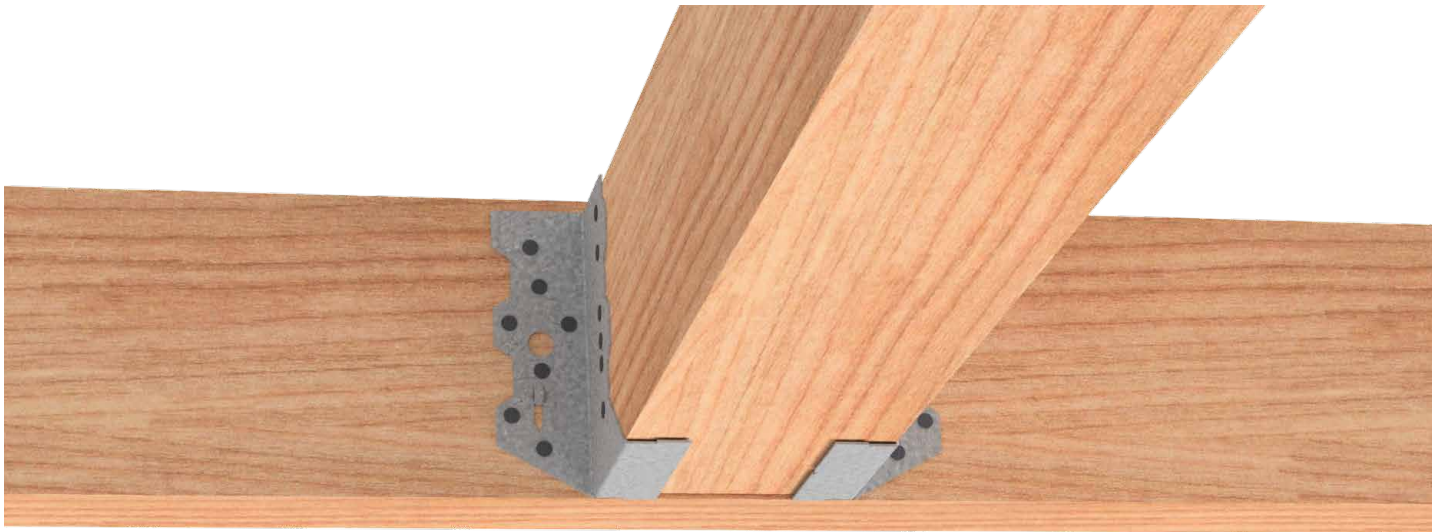

**DESIGN CAPACITY DATA**

Table 1: Design capacity data for Split Joist Hanger [used in pairs]

Sizes	Number of Nails		Type of load	Joint Group					
	Fixing on supporting Beam A	Fixing on supported Beam B		J3	J4	J5	JD3	JD4	JD5
120mm	14 (7 on each side)	11 (6 on left, 5 on right)	Dead Load	4.0	2.8	2.1	5.6	4.0	3.3
			Dead Load + Floor Live Load	4.8	3.4	2.6	6.3	4.8	4.0
			Dead Load + Roof Live Load	5.4	3.8	2.9	7.6	5.4	4.4
			Dead Load + Wind Load	8.0	5.7	4.3	11.2	8.0	6.6
140mm	18 (9 on each side)	13 (7 on left, 6 on right)	Dead Load	4.7	3.3	2.5	6.6	4.7	3.8
			Dead Load + Floor Live Load	5.7	4.0	3.0	7.9	5.7	4.6
			Dead Load + Roof Live Load	6.3	4.5	3.4	8.8	6.3	5.2
			Dead Load + Wind Load	9.4	6.6	5.0	13.1	9.4	7.7
180mm	22 (11 on each side)	15 (8 on left, 7 on right)	Dead Load	5.4	3.8	2.9	7.5	5.4	4.4
			Dead Load + Floor Live Load	6.5	4.6	3.5	9.1	6.5	5.3
			Dead Load + Roof Live Load	7.2	5.1	3.9	10.1	7.2	5.9
			Dead Load + Wind Load	10.7	7.6	5.7	15.0	10.7	8.8
220mm	26 (13 on each side)	17 (9 on left, 8 on right)	Dead Load	6.0	4.3	3.2	8.4	6.0	4.9
			Dead Load + Floor Live Load	7.3	5.2	3.9	10.2	7.3	6.0
			Dead Load + Roof Live Load	8.1	5.7	4.3	11.4	8.1	6.7
			Dead Load + Wind Load	12.0	8.5	6.4	15.8	12.0	9.9

NOTES:

- Design capacities in Table 1 are for VUETRADE 30mm x 2.8mm Ø Galvanised Connector Plate Nails only. Design capacities are determined based on the number of nails in each Split Joist Hanger.
- Modification factors k1 for different load cases are adopted from AS1720.1-2010.
- Design capacities in the Table 1 are based on Category 1 joints where it is applicable for failures that would be unlikely to affect an area of greater than 25m<sup>2</sup>. For Category 2 and Category 3 joints, design capacities from the table are multiplied by 0.941 and 0.882 respectively.
- NEVER punch nails through sheet metal as it results in weaker, non-compliant connections.
- Split Joist Hanger capacities are capped at 15.8kN for steel failure.

