



GALVANISED T-BLADE POST SUPPORT WITH LEG

JUN23

Compliant with the requirements of AS1720.

G GALVANISED

BOLTED TO CONCRETE



CAST INTO CONCRETE

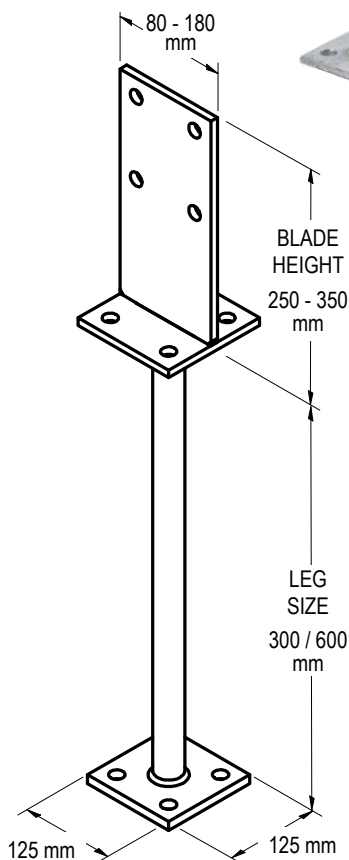

APPLICATION

VUETRADE Galvanised T-Blade Post Supports with Legs are concealed anchors ideal for coastal use, installed by bolting timber posts onto or setting them into concrete.

SPECIFICATION

VUETRADE Galvanised T-Blade Post Supports are manufactured in G300 steel and corrosion protected with Hot Dipped Galvanised.

FASTENERS

Saddle: 4x Zinc-Nickel Coated VUEBOLT or appropriate M12 / M16 bolts with hex nuts*

Base: 4x M12 / M16 concrete bolts or equivalent*

* Based on product size.

SIZES

All VUETRADE T-Blade Post Supports with Legs are 10mm in thickness.

Product Code	Blade Height (mm)	Base Size (mm x mm)	Suits Post Size (mm)	Bolt Size	Leg Dimensions (mm)
VHDBLPS 60080	250	80 x 80	90-100	M12	600 x 35Ø
VHDBLPS 600110	275	110 x 110	115-140	M16	600 x 35Ø
VHDBLPS 300140SOLID	300	140 x 140	150-180	M16	300 x 35Ø
VHDBLPS 600140SOLID	300	140 x 140	150-180	M16	600 x 35Ø
VHDBLPS 600180	350	180 x 180	180-200	M16	600 x 73Ø

* Custom sizes are also available, refer to the VUETRADE T-Blade Post Support with Leg webpage.





GALVANISED T-BLADE POST SUPPORT WITH LEG

JUN23

INSTALLATION GUIDE AND BOLT FIXING SCHEDULE

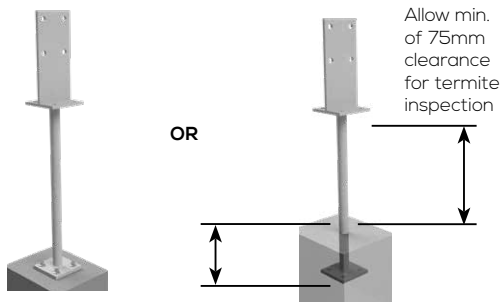
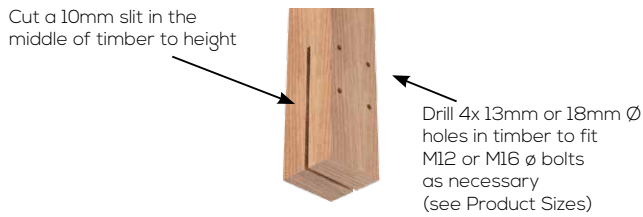

Install 4x appropriate sized concrete bolts (see Product Sizes) or equivalent to ground



Install 4x VUEBOLT or appropriate M12 / M16 bolts fastened with hex nuts



NOTES:

1. Embedment depth of the T-Blade post support should be determined and calculated by a Structural Engineer in order to achieve the reported design load. This usually depends on the type of concrete used, aggregate ratio etc.
2. 75mm clearance must be provided to conform to the requirements set out by AS3660.1:2014 - *Termite management, Part 1: New building work.*

DESIGN CAPACITY DATA

Table 1: Design capacity of T-Blade Post Support with Leg fixed with 4x bolts on various timber joint groups

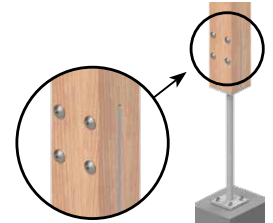

Joint Group	J3	J4	J5	JD3	JD4	JD5
M12 Bolt	47.4	37.7	32.6	57.0	47.4	41.4
M16 Bolt	57.0	57.0	57.0	57.0	57.0	57.0

Table 2: Design capacity of T-Blade Post Support with Leg fixed with 2x bolts on various timber joint groups

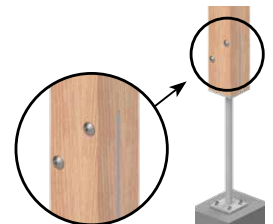

Joint Group	J3	J4	J5	JD3	JD4	JD5
M12 Bolt	23.7	18.8	16.3	29.5	23.7	20.7
M16 Bolt	42.3	33.3	28.8	52.3	42.3	36.7

NOTES:

1. The design capacity of Galvanised T-Blade is capped at 57kN. 57kN is the maximum uplift force from the test carried out before the bolt from the base of the grip failed. At this point, there were no signs of failure in the T-Blade except for minor cupping at its base.
2. The capacities were determined based on loads that are acting parallel to the grain of the timber.
3. Modification factors k_1 for different load cases are adopted from AS1720.1-2010.
4. Design capacities in the above tables are based on Category 1 joints where it is applicable for failures that would be unlikely to affect an area of greater than 25m². For Category 2 and Category 3 joints, design capacities from the table are multiplied by 0.941 and 0.882 respectively.
5. VUETRADE Post Supports should only be used to resist wind uplift / dead load as specified in the TDS and should not be assumed to provide lateral stability. Sufficient bracing should be provided and approved by a structural engineer for lateral stability.
6. Two bolts may be used instead of four, however strength verification must be conducted by a structural engineer to ensure that the two bolt usage is acceptable.
7. If fixing using two bolts, bolts should be fixed using non-adjacent bolt holes (use holes diagonally as shown in figure above).

