



GALVANISED BOLT DOWN POST SUPPORTS

NOV24

Compliant with the requirements of AS1720.

G GALVANISED

BOLTED TO CONCRETE

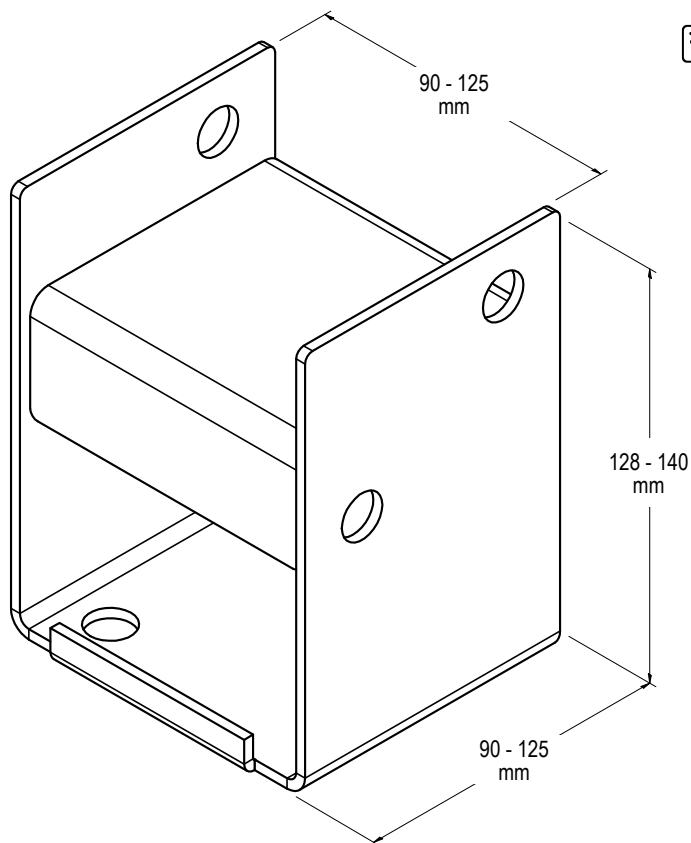

APPLICATION

Bolt Down Post Supports are connectors ideal for strong, concealed bolting of timber posts onto concrete bases.

SPECIFICATION

VUETRADE Galvanised Bolt Down Post Supports are manufactured out of G300 steel with a plate thickness of 3mm (90 and 100mm Bolt Downs) or 4mm (rest of range), and corrosion protected with Hot-Dipped Galvanised as per requirements in AS/NZS 4680:2006.

FASTENERS

Saddle: 2x Zinc-Nickel Coated VUEBOLT or appropriate M12 bolts with hex nuts

Base: 2 / 4x M12 concrete bolts or equivalent in specified bolt holes *

* Stirrup Size 125mm will have 4x bolt holes in base.

SIZES

Product Code	Stirrup Size (mm)	Saddle & Base Thickness (mm)	Box Qty
VBPS90	90	3	10
VBPS100	100	3	10
VBPS115	115	4	10
VBPS125	125	4	10
VBPS100BK *	100	3	10

* BLACKOUT Bolt Down Post Supports are manufactured in 3.0mm steel, corrosion protected with Hot-Dipped Galvanised and then black powder coated.

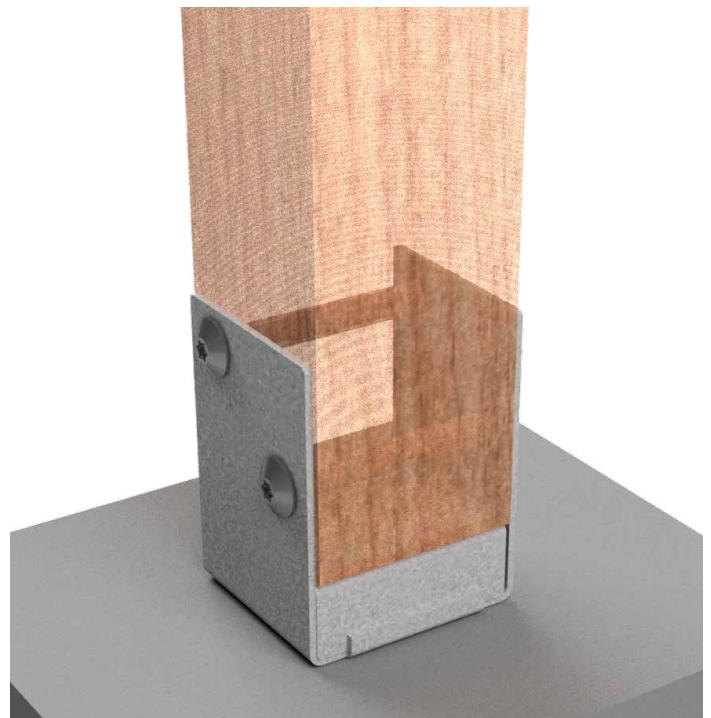



GALVANISED BOLT DOWN POST SUPPORTS

NOV24

INSTALLATION GUIDE AND BOLT FIXING SCHEDULE

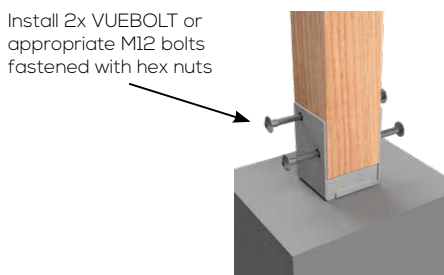
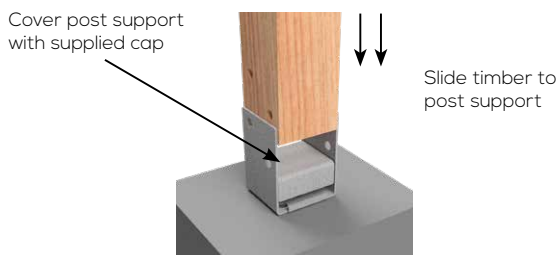
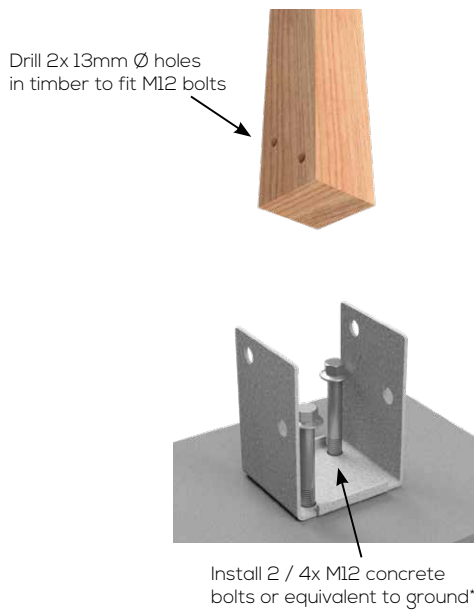

NOTES:

1. Ensure that suitable M12 concrete bolts are used when bolting post support to ground.
2. VUEBOLT may be used as an alternative to standard M12 bolts when fixing post support to timber posts for a concealed and smooth finish.

***ALTERNATIVE METHOD FOR 90mm**

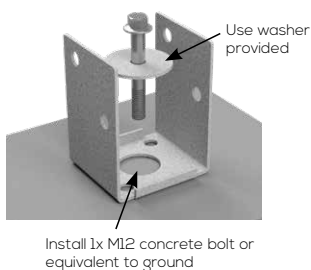

3. The Alternative Method for 90mm Bolt Down Post Supports is suitable when a larger tolerance of adjustment is needed after bolt holes are drilled. Washers are used in this fixing type to provide hold down strength to post support.

DESIGN CAPACITY DATA

Table 1: Design capacities of Bolt Down Post Support on various timber joint groups

Load Case	Design Capacity, N _{dj} (kN)					
	J3	J4	J5	JD3	JD4	JD5
Uplift capacity	9.4	7.5	6.5	11.8	9.4	8.2

NOTES:

1. Design capacity in Table 1 applies to VUETRADE Post Supports where 2x M12 bolts are installed and tightly fastened with hex nuts.
2. Bolts at the base of the post supports must have sufficient anchorage to resist wind uplift.
3. Timber post dimensions must have a minimum dimension of 90mm by 90mm section.
4. Design capacities in Table 1 are for forces in the vertical direction (wind uplifts) only and are obtained under test conditions defined in AS1649-2001 – *Timber - Methods of test for mechanical fasteners and connectors* & uplift capacity requirements outlined in AS1720.1-2010 – *Timber structures, Part 1: Design methods*.
5. VUETRADE Post Supports should only be used to resist wind uplift / dead load as specified in the TDS and should not be assumed to provide lateral stability. Sufficient bracing should be provided and approved by a structural engineer for lateral stability.
6. Design capacity of post support may be limited by the withdrawal tensile capacity of concrete bolts used to fasten post support to concrete ground. Ensure that suitable concrete bolts are used for above design capacity to be valid.

