



# GALVANISED FASCIA BRACKET

NOV24

Compliant with the requirements of AS1684 and AS1720. Designed and tested to AS1649.

**G GALVANISED**

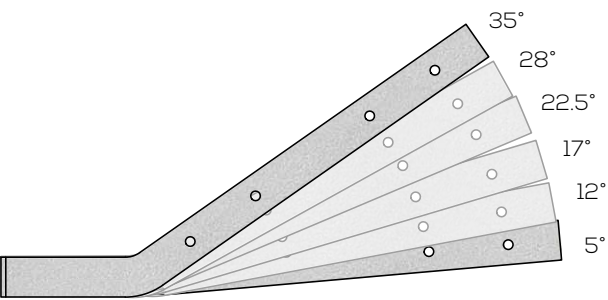

## APPLICATION

VUETRADE Fascia Brackets are commonly used to attach fascia to the rafters and are available in six standard angles.

## SPECIFICATION

VUETRADE Fascia Brackets are manufactured using 6.5mm G300 steel and Hot-Dipped Galvanised to HDG600.

## FASTENERS

- Rafters blade:** 4x appropriate M10 bolts with hex nuts and washers
- Fascia base:** 2x appropriate M10 bolts with hex nuts and washers

## SIZES

Product Code	Angle	Neck Length	Box Qty
VTHDFB05	5°	150mm	6
VTHDFB12	12°	150mm	6
VTHDFB17	17°	150mm	6
VTHDFB22	22.5°	150mm	6
VTHDFB28	28°	150mm	6
VTHDFB35	35°	150mm	6
VTHDFB17L	17°	220mm	6
VTHDFB22L	22.5°	220mm	6
VTHDFB28L	28°	220mm	6

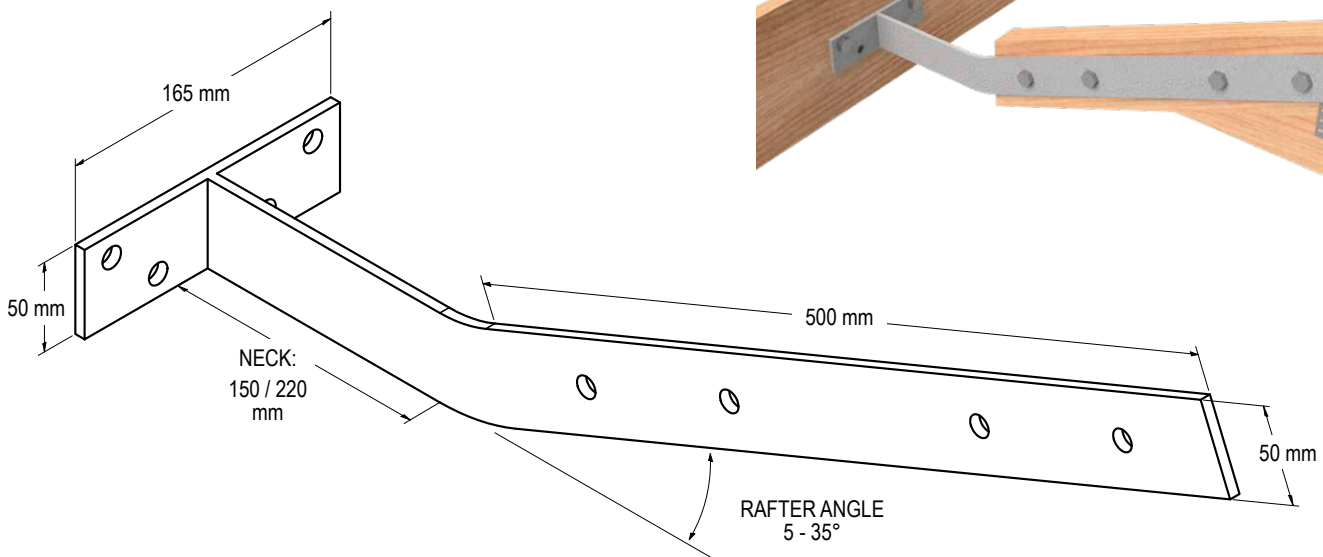



**GALVANISED FASCIA BRACKET**

NOV24

**INSTALLATION GUIDE AND BOLT FIXING SCHEDULE**

Drill 4x 12mm Ø holes in rafter to fit M10 bolts

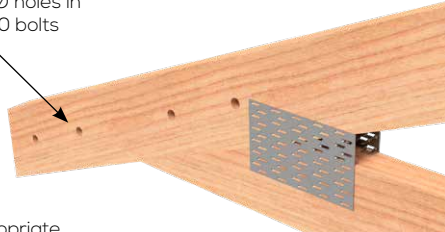

Install 4x appropriate M10 bolts to rafter and washers on the timber side along with hex nuts

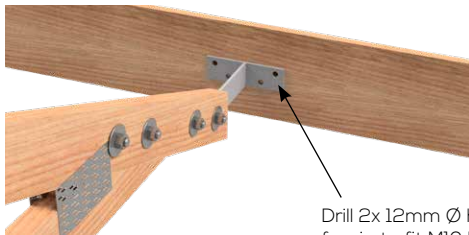
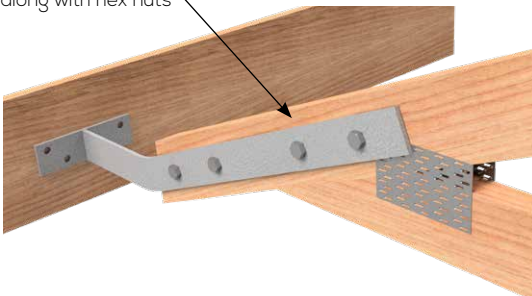

Drill 2x 12mm Ø holes in fascia to fit M10 bolts

Install 2x appropriate M10 bolts to fascia of a minimum size 90x35mm; washer and hex nut as appropriate

**NOTES:**

1. Washers suitable are 2.5mm thick, 45mm Ø round or 40 x 40mm square in size and used on the timber side only.

**DESIGN CAPACITY DATA**

Table 1: Design capacity of Fascia Brackets when secured with 4x bolts

Timber Thickness (mm)	Design Capacity, N <sub>dj</sub> (kN)		
	JD3	JD4	JD5
<b>35</b>	5.8	4.2	3.1
<b>45</b>	7.4	5.4	3.9

**NOTES:**

1. Design load given in Table 1 are for long-term dead load of 1.35G, with duration of load factor k<sub>1</sub> = 0.57. Duration of load for other load case shall refer to AS1720.1.
2. The angle of the fascia brackets does not influence the design capacity of the bolts.
3. Overhang of rafter/trusses must be adequately designed for this additional applied load imposed by verandah/ pergola by a structural engineer. Overloaded trusses/rafter may lead to premature failure of the structures.
4. Edge and end distance for bolt on timber must adhere to requirements set out by AS1720.1 section 4.4.4.
  - a. 70mm from timber end
  - b. 20mm from timber edge

