



GALVANISED JOIST HANGERS

NOV24

Compliant with the requirements of AS1684 and AS1720. Designed and tested to AS1649.

G GALVANISED

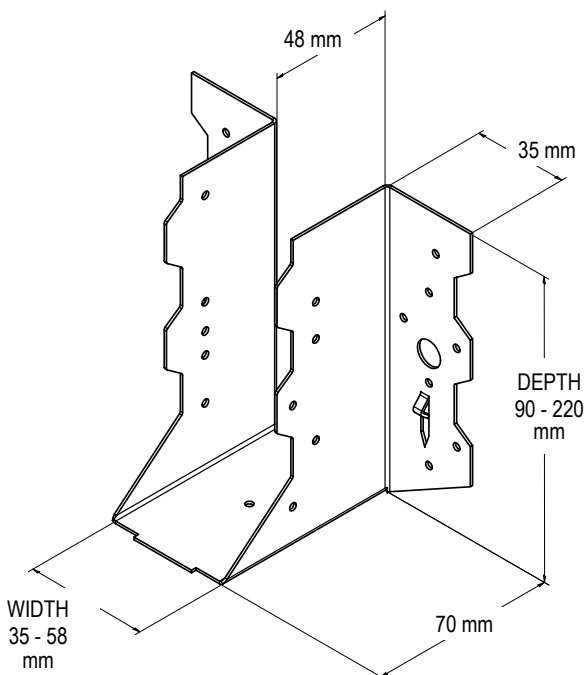
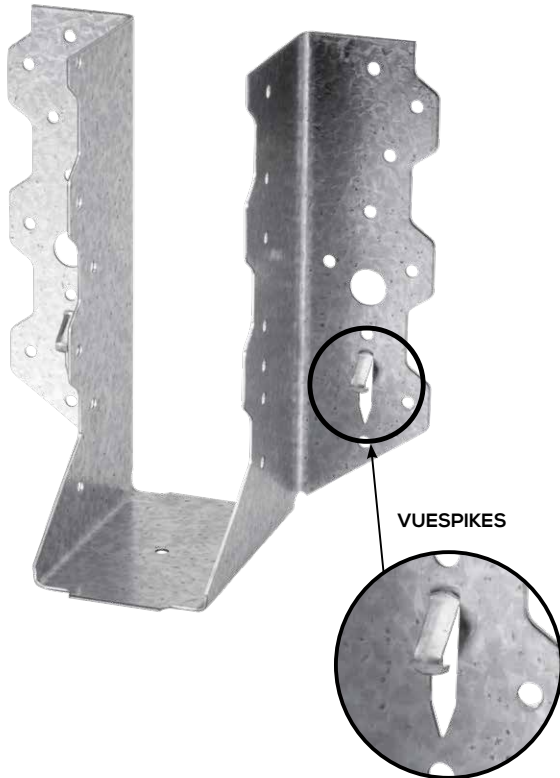

APPLICATION

VUETRADE Galvanised Joist Hangers are manufactured with VUESPIKES for easy and fast installation.

SPECIFICATION

VUETRADE Galvanised Joist Hangers are manufactured from G300 Z275 galvanised steel in 1.0 mm thickness (TCT).

FASTENERS

Nails: Use VUETRADE 30mm x 2.8mm Ø Galvanised Connector Plate Nails **OR:**

Screws: VUETRADE Type 17 12G x 35mm screws.

SIZES

Product Code	Nominal Size (mm)	Box Qty
VJH3590	35 x 90	45
VJH35120	35 x 120	30
VJH35140	35 x 140	30
VJH35180	35 x 180	30
VJH3890	38 x 90	45
VJH38120	38 x 120	30
VJH38140	38 x 140	30
VJH38180	38 x 180	30
VJH4590	45 x 90	45
VJH45120	45 x 120	30
VJH4590	45 x 90	45
VJH45180	45 x 180	30
VJH45220	45 x 220	20
VJH5090	50 x 90	45
VJH50120	50 x 120	30
VJH50140	50 x 140	30
VJH50180	50 x 180	30
VJH50220	50 x 220	20
VJH58180	58 x 180	30
VJH4590BK *	45 x 90	20
VJH45140BK *	45 x 140	20



* BLACKOUT Joist Hangers are manufactured in 1.0mm G300 Z275 galvanised steel with black powder coating.





GALVANISED JOIST HANGERS

NOV24

INSTALLATION GUIDE

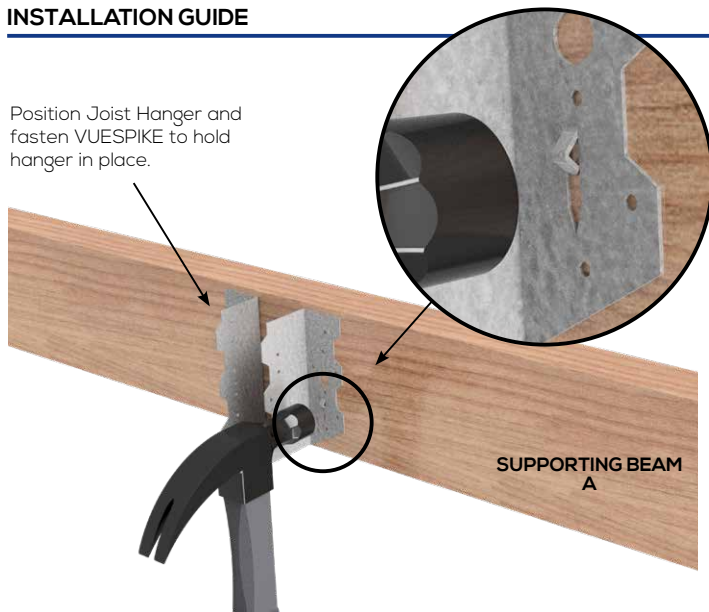

1. Suitable size Joist Hanger shall be selected using size table on previous page, ensuring sufficient hanger depth is provided for different joist / beam sizes.
2. Joist Hanger should be fixed to the supporting member first. It can be quickly and easily held in place by VUESPIKES before fastening hanger with nails.
3. Fix VUETRADE 30mm x 2.8mm Ø Galvanised Connector Plate Nails or VUETRADE Type 17 12G x 35mm screws through Joist Hanger to supporting beam, using the recommended number of fixings listed in Table 1 or 2.
4. Install supported beam (usually floor beams / joists) to hangers and fasten supported beams with VUETRADE 30mm x 2.8mm Ø Galvanised Connector Plate Nails or VUETRADE Type 17 12G x 35mm screws, using recommended number of fixings listed in Table 1 or 2.

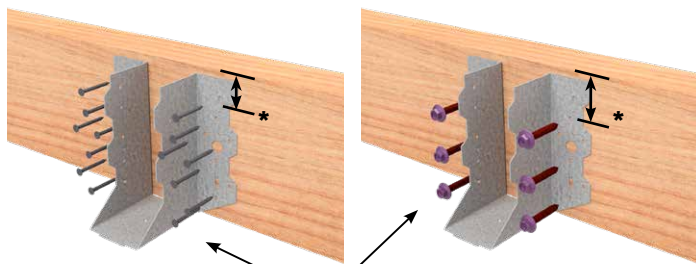

Fix Joist Hanger with 30mm x 2.8mm Ø Galvanised Connector Plate Nails or VUETRADE Type 17 12G x 35mm screws to supporting beam A

* Ensure minimum distance to edge of timber from the nearest fastener is no closer than 30mm (screws) or 17mm (nails).

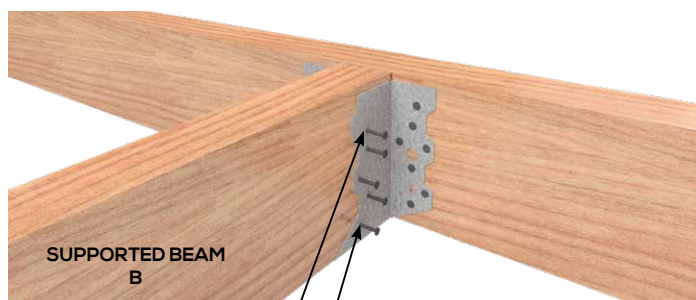
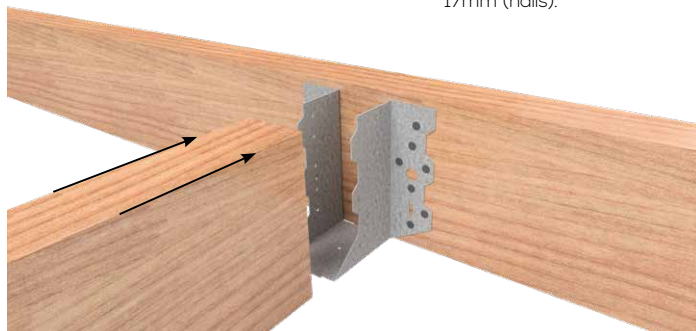
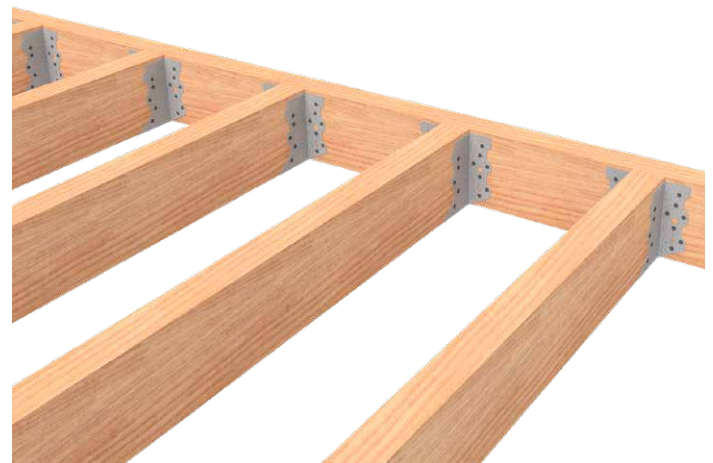

Fix supported beam B to Joist Hanger with VUETRADE 30mm x 2.8mm Ø Galvanised Connector Plate Nails or VUETRADE Type 17 12G x 35mm screws



GALVANISED JOIST HANGERS

NOV24

DESIGN CAPACITY DATA
Table 1: Design Capacity data for nail fixing of Joist Hanger

Sizes	Number of Nails		Type of load	Joint Group					
	Fixing on supporting Beam A	Fixing on supported Beam B		J3	J4	J5	JD3	JD4	JD5
90mm	10	8	Dead Load	3.9	2.7	2.1	5.4	3.9	3.2
			Dead Load + Floor Live Load	4.7	3.3	2.5	6.5	4.7	3.8
			Dead Load + Roof Live Load	5.2	3.7	2.8	7.3	5.2	4.3
			Dead Load + Wind Load	6.2	4.4	3.3	8.7	6.2	5.1
120mm	14	10	Dead Load	4.8	3.4	2.5	7.1	5.0	4.1
			Dead Load + Floor Live Load	5.8	4.1	3.1	8.5	6.1	5.0
			Dead Load + Roof Live Load	6.4	4.5	3.4	9.5	6.8	5.6
			Dead Load + Wind Load	7.7	5.5	4.1	10.8	7.7	6.3
140mm	18	12	Dead Load	5.8	4.1	3.1	8.9	6.4	5.2
			Dead Load + Floor Live Load	7.1	5.0	3.8	10.8	7.7	6.3
			Dead Load + Roof Live Load	7.9	5.6	4.2	12.0	8.6	7.1
			Dead Load + Wind Load	8.6	6.1	4.6	11.4	8.2	6.7
180mm	22	14	Dead Load	6.8	4.8	3.6	10.7	7.7	6.3
			Dead Load + Floor Live Load	8.2	5.8	4.4	13.0	9.3	7.6
			Dead Load + Roof Live Load	9.2	6.5	4.9	14.5	10.3	8.5
			Dead Load + Wind Load	9.1	6.4	4.9	13.9	9.9	8.1
220mm	26	18	Dead Load	7.9	5.6	4.2	12.4	8.9	7.3
			Dead Load + Floor Live Load	9.6	6.8	5.1	15.1	10.8	8.8
			Dead Load + Roof Live Load	10.7	7.5	5.7	16.8	12.0	9.8
			Dead Load + Wind Load	12.6	8.9	6.7	16.0	11.4	9.4

Please see notes on following page underneath Table 2.



GALVANISED JOIST HANGERS

NOV24

DESIGN CAPACITY DATA
Table 2: Design Capacity data for screw fixing of Joist Hanger

Sizes	Number of Screws		Type of load	Joint Group		
	Fixing on supporting Beam A	Fixing on supported Beam B		JD3	JD4	JD5
90mm	4	4	Dead Load	5.4	4.9	3.5
			Dead Load + Floor Live Load	6.5	5.9	4.2
			Dead Load + Roof Live Load	7.3	6.6	4.7
			Dead Load + Wind Load	8.7	9.8	6.9
120mm	6	4	Dead Load	7.4	7.4	5.2
			Dead Load + Floor Live Load	8.9	8.9	6.3
			Dead Load + Roof Live Load	9.9	9.9	7.0
			Dead Load + Wind Load	9.8	9.8	6.9
140mm	6	4	Dead Load	8.9	7.4	5.2
			Dead Load + Floor Live Load	10.8	8.9	6.3
			Dead Load + Roof Live Load	12.0	9.9	7.0
			Dead Load + Wind Load	12.1	9.8	6.9
180mm	8	6	Dead Load	10.7	9.8	6.9
			Dead Load + Floor Live Load	13.0	11.9	8.4
			Dead Load + Roof Live Load	14.5	13.2	9.4
			Dead Load + Wind Load	14.7	14.7	10.4
220mm	10	8	Dead Load	12.5	11.5	8.2
			Dead Load + Floor Live Load	15.1	13.9	9.9
			Dead Load + Roof Live Load	16.9	15.6	11.0
			Dead Load + Wind Load	19.6	19.6	13.9

NOTES:

- Capacities tabulated above are for supporting beam (Beam A) to be minimum of 35mm thickness.
- Design capacities in Table 1 are based on Category 1 joints where it is applicable for failures that would be unlikely to affect an area of greater than 25m². For Category 2 and Category 3 joints, design capacities from the table are multiplied by 0.941 and 0.882 respectively.
- Ensure that the Joist Hanger covers at least 60% of the depth of the supported member, unless additional lateral restraint on the top of supported member is provided.
- Supporting beams/trusses made from multiple ply must be laminated and fastened together as per AS1684. Joist Hangers fixed with screws must use 65mm length screws in lieu of 35mm to fix into double ply beams/trusses unless advised otherwise. Alternative fixing to laminate multiple ply beams/trusses shall be provided by relevant engineering authorities.
- Fixing of Joist Hangers with VUETRADE connector plate screws to follow fixing configuration supplied in this document to ensure proper load distribution and spacing are adhered to.
- VUETRADE strongly recommends all timber connector products are installed as per the installation instructions on the relevant Technical Data Sheet, using the recommended type and quantity of fasteners.
- It is critical to confirm that any fastening method is in accordance with local building standards. For further information on installation options, refer to the VUETRADE Technical Guidelines on Fastening Methods.





GALVANISED JOIST HANGERS

NOV24



VUETRADE TYPE 17 12G X 35mm MINIMUM SCREW FASTENING METHOD

90mm

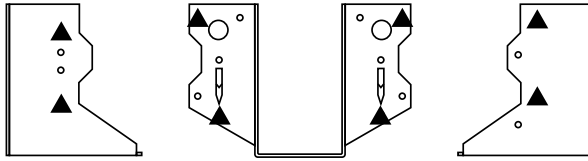

120mm

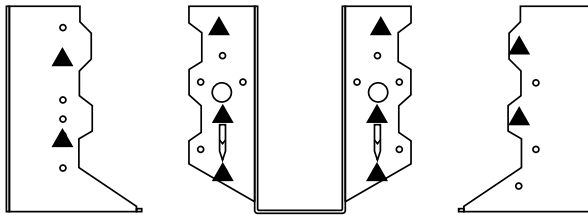

140mm

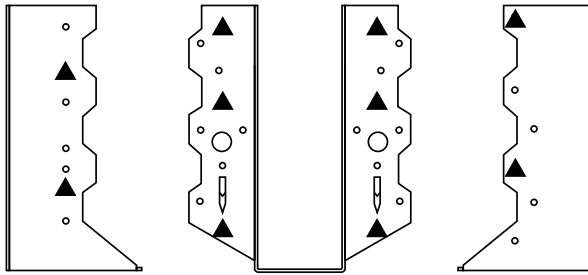

180mm

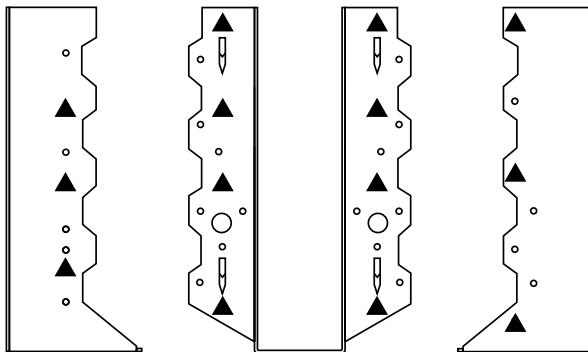

220mm

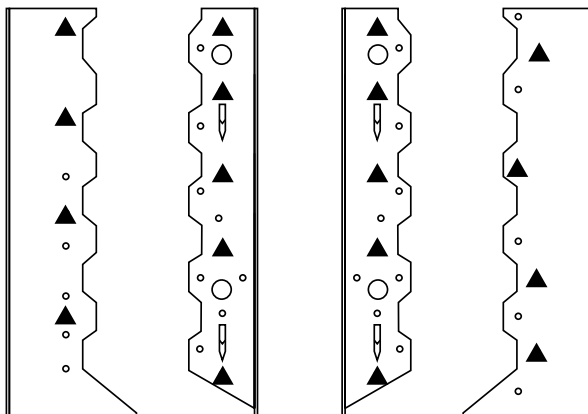

Fastening quantities detailed are the minimum recommended, and meet the design capacities when installed with even spacing after meeting initial timber edge requirements.

Changing fastening methods and / or listed quantities to any method other than that which is illustrated is with users discretion.

