



GALVANISED DOUBLE SLEEVE EXPANSION TIES

MAR25

Compliant with the requirements of AS2699 and AS3700.

G GALVANISED

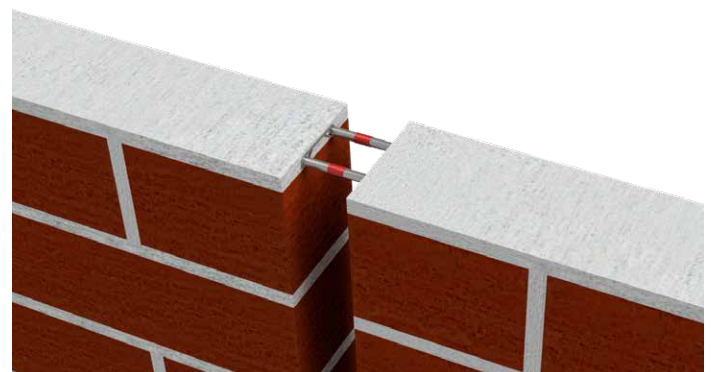
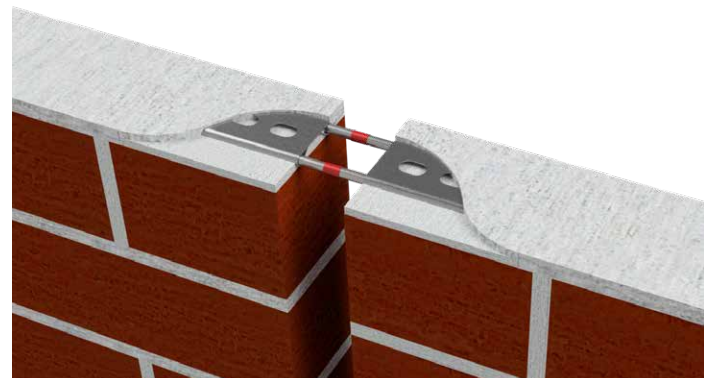
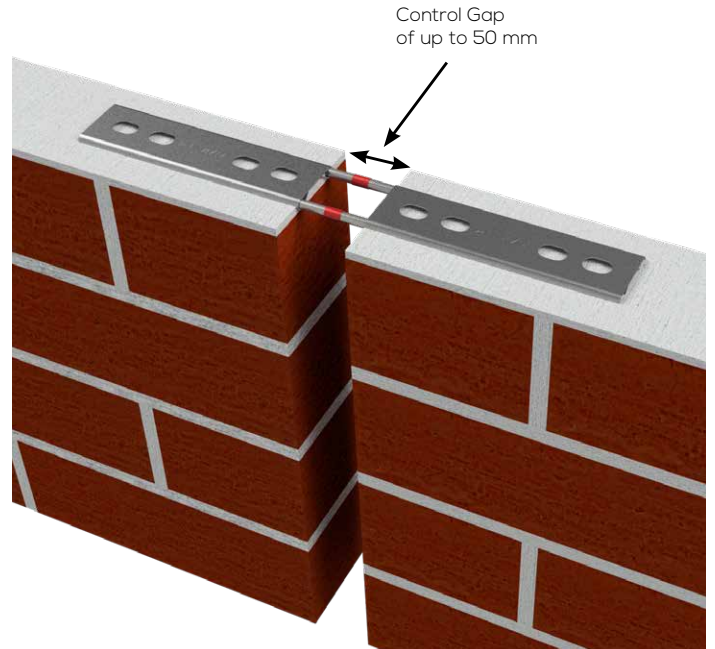
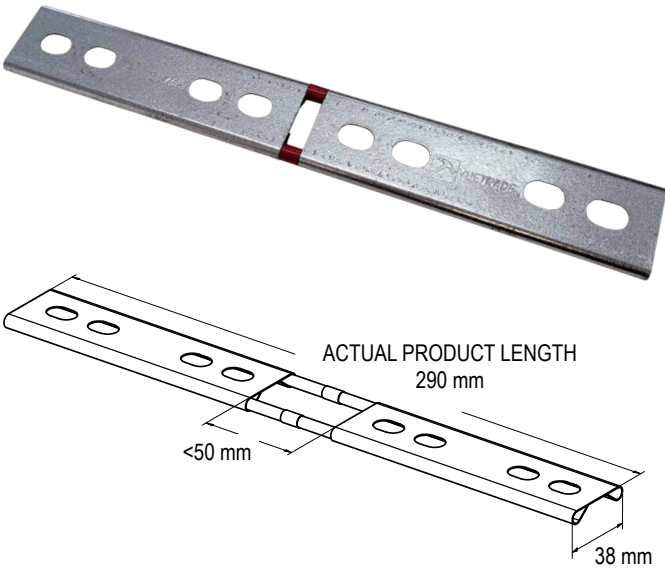

APPLICATION

VUETRADE Double Sleeve Expansion Ties are a rod tie designed for vertical expansion joints. The rods have a metal sleeve on each end which is laid into either side of the construction joint allowing movement.

SPECIFICATION

- Bar Diameter:** 5.5mm
- Material:** G300 Z600

DURABILITY

VUETRADE Double Sleeve Expansion Ties complies with the durability classification of AS2699.1:2020 as follow:

VTDSG (Galvanised): Durability classification R2

SIZES

Product Code	Maximum Control Gap	Durability Classification	Box Qty
VTDSG	50mm	R2	50

R2 DURABILITY CLASSIFICATION
10km or further from breaking surf,
or 1km or further to sheltered coastal





GALVANISED DOUBLE SLEEVE EXPANSION TIES

MAR25

National Construction Code 2022 – ABCB Housing Provisions

Table 5.6.5d from ABCB Housing Provisions of the NCC 2022 provides corrosion protection requirements for masonry wall ties in different exposure conditions along with recommended corrosion protections.

Table 5.6.5d Corrosion protection for wall ties

Exposure condition	Tie specification (minimum corrosion protection)
Areas less than 1km from breaking surf; or less than 100 m from salt water not subject to breaking surf; or within heavy industrial areas.	Grade 316L stainless steel; or engineered polymer complying with the requirements of AS 2699.1.
Areas 1km or more but less than 10km from breaking surf; or 100m or more but less than 1km from salt water not subject to breaking surf.	Sheet steel and bar ties galvanised after manufacture - 470 g/m ² on each side; or galvanised wire ties - 470 g/m ² coating mass; or Grade 304L stainless steel.
All other areas	Galvanised sheet steel - 300 g/m ² coating on each side; or sheet steel ties galvanised after manufacture - 300 g/m ² on each side.

© Commonwealth of Australia and the States and Territories 2022, published by the Australian Building Codes Board.

SELECTION OF SUITABLE CORROSION PROTECTION ON VUETRADE PRODUCTS

Majority of VUETRADE products are adequately corrosion protected to meet all corrosion protection standards mentioned in previous section and are categorized into three main categories.



STANDARD / GALVANISED

- Internal / enclosed
- Exterior/exposed inland areas except if in contact with fresh water or non-saline wetting & drying



MARINE ENVIRONMENT – SS304

- Marine Environment – 100m up to 1km from a non-surf coast and from 1km up to 10km from a surf coast
- External applications in contact with freshwater or subject to non-saline wetting and drying
- Minimum steel grade required Stainless Steel 304



SEVERE MARINE – SS316

- Severe Marine – 100m from a non-surf coast and up to 1km from a surf coast
- Minimum Steel Grade Stainless Steel 316
- No 'Tea Staining', a superficial 'rust' look that occurs on lower grades of Stainless Steel including 304.

Using the chart, the level of corrosion protection needed can be easily identified. It is highly recommended to adhere and comply to the minimum requirement of corrosion protection as failure to do so may lead to severe corrosion that will critically affect the structural integrity of a building.

These classifications are based on AS2699.1:2020.

