



GALVANISED HEAVY DUTY U-CUP BOLT DOWN POST SUPPORTS

JUN26

Compliant with the requirements of AS1720.

G GALVANISED

CYCLONIC

BOLTED TO CONCRETE



APPLICATION

Heavy Duty U-Cup Bolt Down Post Supports are heavy duty anchors ideal for bolting timber posts to existing timber decking or concrete bases.

SPECIFICATION

VUETRADE Heavy Duty U-Cup Bolt Down Post Support are manufactured from 4mm thick G300 steel and corrosion protected with Hot Dipped Galvanised. Available in wide range of sizes to suit many common timber post sizes.

FASTENERS

Saddle: 2x VUEBOLT or appropriate M12 bolts with hex nuts

Base: 2x M12 concrete bolts or equivalent

SIZES

Product Code	Size (mm)	Bolt Size	Box Qty
VHDBPS75	75	M12	10
VHDBPS90	90	M12	10
VHDBPS100	100	M12	10
VHDBPS115	115	M12	10
VHDBPS125	125	M12	10
VHDBPS140	140	M12	10
VHDBPS150	150	M12	10

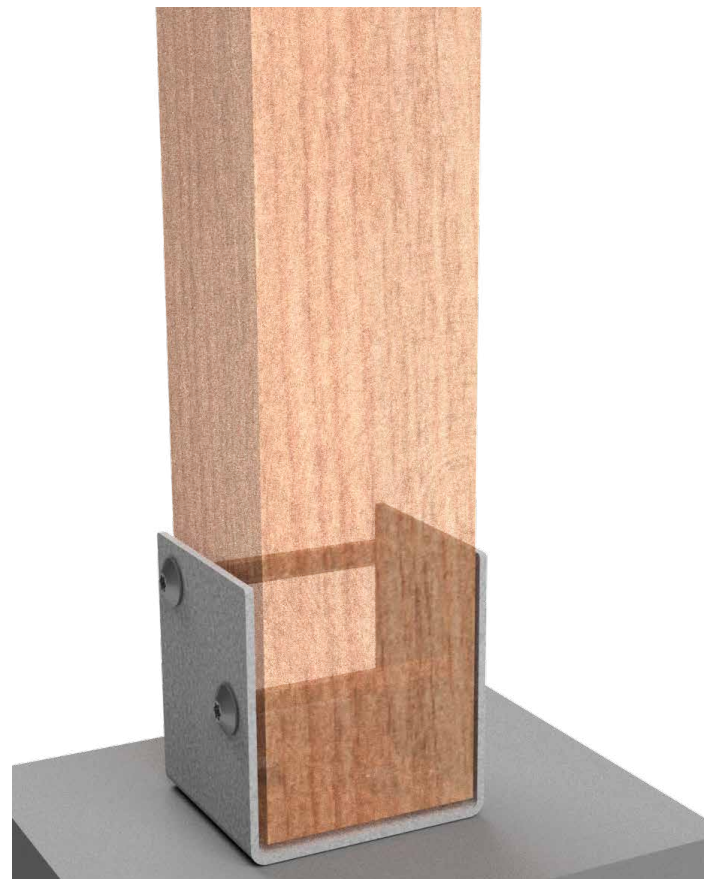
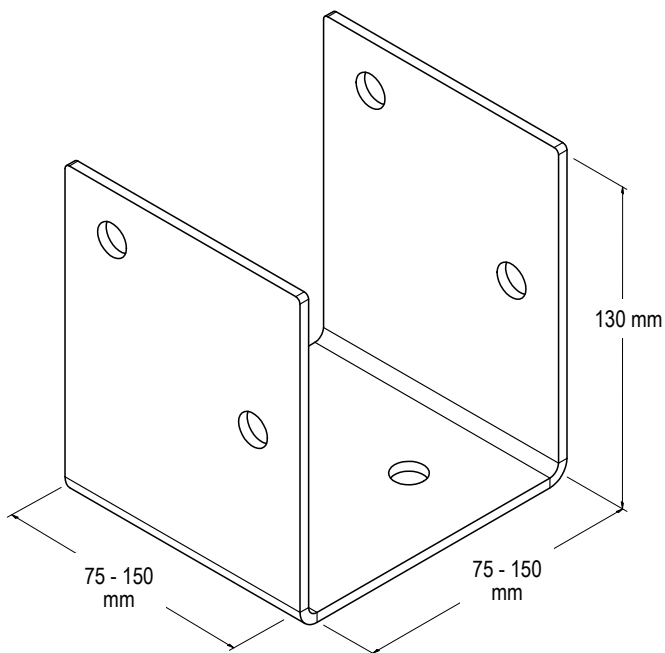



GALVANISED HEAVY DUTY U-CUP BOLT DOWN POST SUPPORTS

JUN26

INSTALLATION GUIDE AND BOLT FIXING SCHEDULE

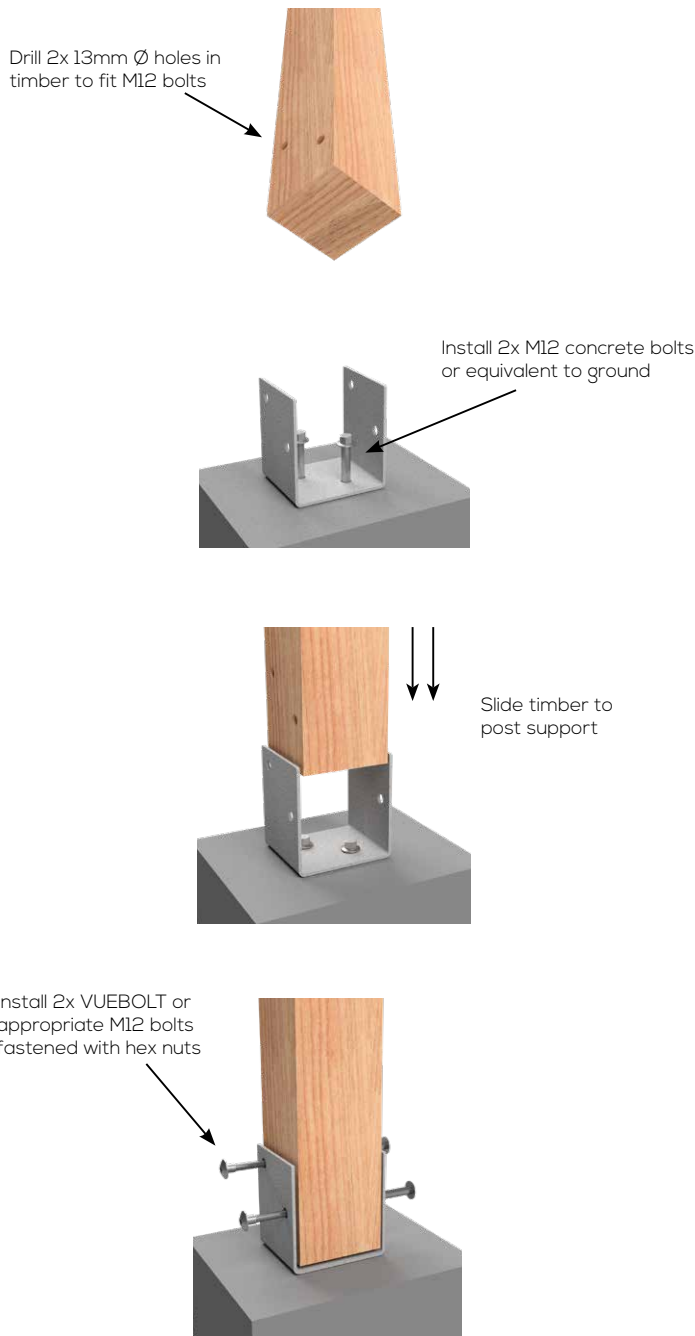

1. Ensure that suitable M12 concrete bolts are used when bolting post support to ground.
2. Use only galvanised bolts with galvanised post support, usage of other steel materials bolt with galvanised post support may lead to bimetallic corrosion.
3. Fixing of VUEBOLT may be used as an alternative to standard M12 bolts when fixing post support to timber posts for smooth architectural finish.

DESIGN CAPACITY DATA

Table 1: Design capacities of Heavy Duty U-Cup Bolt Down Post Support

Load Case	Design Capacity, Ndj (kN)					
	J3	J4	J5	JD3	JD4	JD5
Uplift capacity	15.0	13.4	11.6	15.0	15.0	14.7

NOTES:

1. Design capacity in Table 1 applies to VUETRADE Heavy Duty U-Cup Bolt Down Post Supports where 2x M12 VUEBOLTS / appropriate bolts are installed and tightly fastened with hex nuts.
2. Timber posts must have minimum dimensions of 90mm by 90mm section and shall be installed flat to the base of the post support.
3. Footings by others.
 - a. Design capacities for post supports bolted or cast into concrete assumed that there is sufficient anchorage to resist wind uplift.
 - b. Design capacity of this post support may be limited by the withdrawal tensile capacity of concrete bolts used to fasten post support to concrete ground. Ensure that suitable concrete bolts are used for above design capacities to be valid.
4. Design capacities in the above table are for wind uplift (vertical force direction) only and are obtained under strict in-house test conditions defined by AS1649:2025 - Timber - Methods of test for mechanical fasteners and connectors & uplift capacity requirements outlined in AS1720.1-2010 - Timber structures, Part 1: Design methods.
5. VUETRADE Post Supports should only be used to resist wind uplift / dead load as specified in the TDS and should not be assumed to provide lateral stability. Sufficient bracing should be provided and approved by a structural engineer for lateral stability.
7. Design capacity in Table 1 are based on Category 1 joints where it is applicable for failures that would be unlikely to affect an area of greater than 25m². For Category 2 and Category 3 joints, design capacities in this table are modified by multiplying 0.941 and 0.882 respectively.

